

REV.	ECN NO.	DESCRIPTION	DESIGN	DATE
A		INITIAL	Kai	2018.03.29

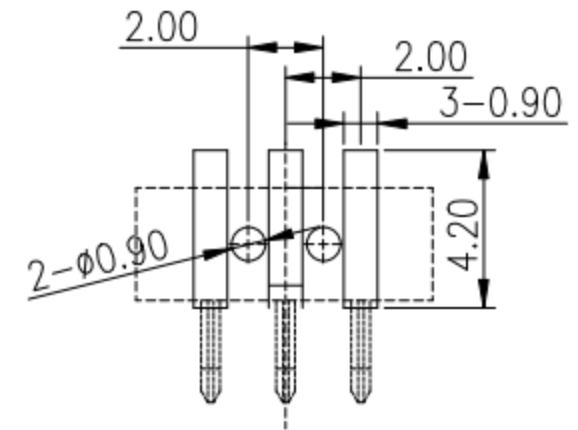

RECOMMENDED P.C.B LAYOUT  
TOP VIEW (.XX±0.05)

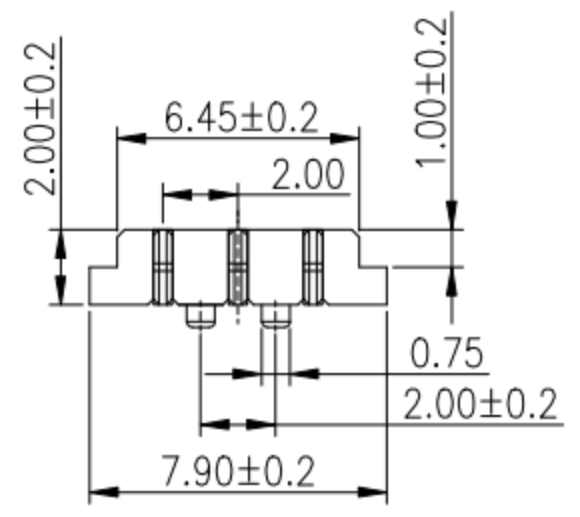
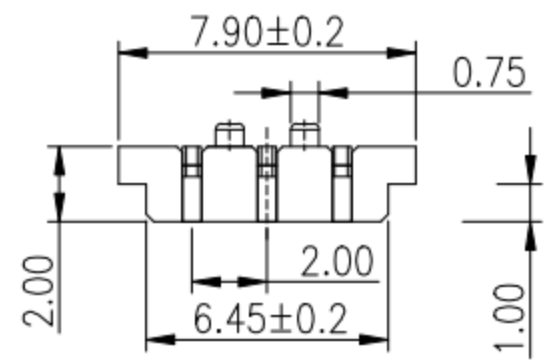
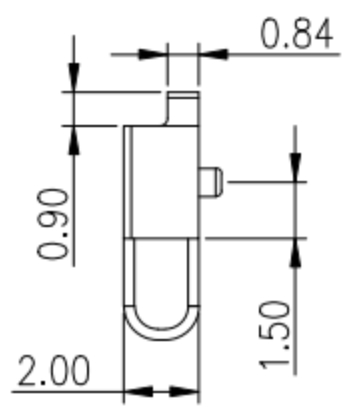
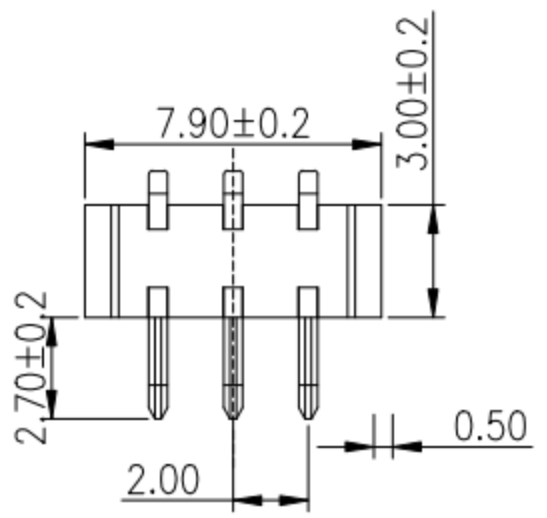

NOTE:  
Material  
Insulator:Nylon 9T(UL94V-0)  
Contact:phosphor Bronze  
Contact Plated:Gold over Nickel or Tin  
Specification  
Rated voltage: 12V 30V  
Current rating: 3A 5A  
instant CURRENT:7A  
Contact Resistance:30MΩ  
Insulation Resistance:100MΩ  
Dielectric Voltage:1000V  
Operdting Temperature:-40°~105°

UNLESS OTHERWISE SPECIFIED TOLERANCES				东莞市高迪电子有限公司			
DECIMALS:		ANGLES:					
DIM	TOL	DIM	TOL	DESIGN:	PART NO.		
X.	±0.50	X.	±2'	CHECK:	REV. UNIT: SHEET:		
X.X	±0.30	X.X	±1'	APPROVED	A	mm 1/1	
X.XX	±0.20	X.XX					
X.XXX	±0.10	X.XXX					

②	HOUSING	1	LCP		BLACK
①	CONTACT A	2	PHOSPHOR BRONZE 0.20T	Au PLATED	
ITEM	PART NAME	Q'TY	MATERTAL	DESCRIPTION	REMARK